



300

716 Dump



KEY FEATURES

- Wide Cabin
- Dual SRS Airbags
- ABS Brakes with Electronic Brakeforce Distribution
- Easy Start – Take Off Assist
- ADR 80/02 Compliant
- Ventilated Disc Brakes
- Corner Turning Lamps
- Energy Absorbing Steering Wheel
- Factory Dump 3.0m³
- Two-way Tail Gate with Drop Sides

KEY SPECIFICATIONS

- GVM** 6500kg, optional 4495kg
- GCM** 10,000kg, optional 7995kg
- Engine** . . . 4.0-litre, Common Rail, Direct Injection,
. Turbocharged and Intercooled
- Power** 110kW @ 2700rpm (ISO)
- Torque** 397Nm @ 1800rpm (ISO)
- Wheelbase** 3430mm





716 Dump

Engine, Driveline & Chassis specifications

ENGINE

Engine	Hino N04C TV
Max output (ISO Net)	110kW at 2700rpm
Max torque (ISO Net)	397Nm at 1800rpm
Maximum engine speed	3200rpm
Type	Diesel, four cycle, four-cylinder in line, overhead valve, water cooled
Combustion system	Direct injection type
Bore & stroke	104 x 118mm
Piston displacement	4.009 litres
Fuel injection system	Electronic control, common rail type
Air intake system	Turbo-intercooled, stack-type air intake
Air cleaner	Paper element
Fan clutch	Equipped
Catalytic converter	Equipped
Exhaust outlet	Horizontal

TRANSMISSION

Model	MY6S
Type	Six-speed overdrive manual, synchromesh on all gears including reverse

CLUTCH

Type	Dry single plate, diaphragm type with damper springs
Facing material	Semi-mould
Facing outside diameter	325mm
Facing lining area	483 x 2cm ²
Control	Hydraulic with vacuum booster
PTO	Transmission PTO
Hydraulic pump	Gear type
PTO & dump control	Lever in cabin

BRAKES

Service brakes	Hydraulic system with ventilated disc brakes front and rear
Control	Vacuum servo with hydraulic assist & dual circuits
Front disc diameter	296mm
Rear disc diameter	287mm
Anti-lock system (ABS)	Equipped
Electronic Brakeforce Distribution (EBD)	Equipped
Easy Start system	Equipped
Exhaust brake	Electric-vacuum actuator with valve in exhaust pipe

PERFORMANCE & GEAR RATIOS

Maximum speed (km/h)	119
Gradeability tan θ %	51.9

1st	5.979	5th	1.000
2nd	3.434	6th	0.759
3rd	1.862	Rev.	5.701
4th	1.297		

Final drive ratio 4.875:1

AXLE LOAD & TYRE LOAD LIMITS

Front axle	3100kg
Tyres	2570kg
Rear axle	5100kg
Tyres	4860kg
Front axle type	Reversed Elliot, "I" section beam
Rear axle type	Full-floating, single reduction, single speed by Hypoid gears

SUSPENSION

Front suspension	Semi-elliptic tapered leaf springs with silencers, shock absorbers and stabiliser bar
Spring dimensions, span & width	1250mm x 70mm
Rear suspension	Semi-elliptic main and auxiliary tapered leaf springs with silencers and shock absorbers
Spring dimensions, span & width	1300mm x 70mm
Auxiliary springs	900mm x 70mm

WHEEL & TYRES

Wheel type	6-stud disc wheel
Wheel & rim size	205/85R16 117/115 & 16x5.5K – 115mm
Number of tyres	Seven including spare
Spare tyre carrier	Equipped

ELECTRICAL

Type	24 volt, negative earth
Batteries	12V x 2, series connected
Alternator type	Built-in rectifier and voltage regulator
Capacity	24V – 60A
Starter capacity	24V, 4.5kW

CHASSIS FRAME

Type	Ladder-shaped channel section side rails
Chassis width at rear	750mm
Max. section (depth x flange x thickness)	192.8 x 65 x 5.9mm
Tensile strength	540N/mm ²
Towing hooks	Equipped at front and rear
Front bumper	Painted to cabin colour



716 Dump

Cab equipment & Instrumentation

POWER & TORQUE CHART (ISO Net)

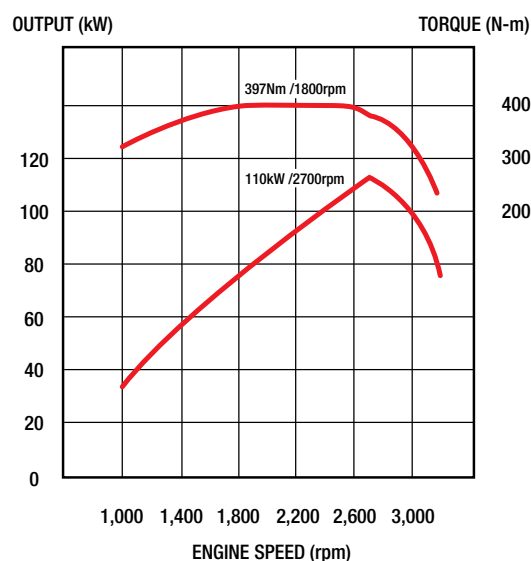

CAB EXTERIOR

Type	Forward control, all steel welded construction, torsion-bar tilt mechanism, fully trimmed
Windscreen wipers	Electric, dual wipers, intermittent and 2-speed
Outside rear mirrors	Two, movable flat type
Radiator grille	Painted same colour as cabin
Lamps	Halogen headlamps, cornering lamps, fog lamps

CAB INTERIOR

Steering	Telescopic tilt column with integral power steering
Windscreen glass	Laminated glass
Seating capacity	Three
Driver's seat	2-way adjustable, urethane foam pads, high-back seat
Assistant's seat	Fixed, urethane foam pads, high-back seat
Seat cover	Fabric cover
Seat belts	
Driver's seat	3-point type with ELR and pre-tensioner
Assistant's seat	3-point type with ELR and pre-tensioner
Centre passenger's seat	2-point type
Sun visors	For driver and passenger
Ventilator	Forced type by electric blower
Inside rear mirror	One, flat type
Cigarette lighter (24 volt)	Equipped
Audio	AM/FM radio with CD player
Heater and defroster	Equipped
Air conditioner	Equipped
Auto door lock	Equipped
Power windows	Equipped
SRS airbags	Equipped for driver and assistant
Seat back console	Equipped (centre)
Overhead consoles	For driver and assistant
Ash tray 1-pc.	Equipped
Door pockets (both sides)	Equipped
Assist grip	Equipped
Coat hook	Equipped
Card holder	Equipped
Pen holder	Equipped
Cup holder	Equipped

DUMP BODY

Capacity	3.0m ³
Dump angle	60 degrees

INSTRUMENTS

1. Meter and gauges

- km-kg system
- Speedometer with odometer and 2 trip meters
- Fuel gauge
- Coolant temperature gauge
- Engine tachometer

2. Warning, pilot lamps and buzzers

- Turning signal & hazard indicator lamp
- Exhaust brake indicator lamp
- Engine oil pressure warning lamp
- Battery charge warning lamp
- Beam indicator lamp
- Parking brake indicator lamp
- Engine malfunction indicator lamp
- Fuel level warning lamp
- Fuel filter water accumulating level warning lamp
- Brake fluid level warning lamp
- Back-up warning buzzer
- ABS system failure warning lamp
- SRS airbag system failure warning lamp
- Easy Start indicator lamp

3. Switches

- Lighting switch
- Directional indicator, dimmer, passing switch
- Room lamp switch
- Hazard lamp switch
- Wiper and washer switch
- Exhaust brake switch
- Easy Start switch
- Easy Start release timing adjuster switch

4. Others

- One-key starting-stopping
- Horn button
- Remote keyless entry



716 Dump Dimensions

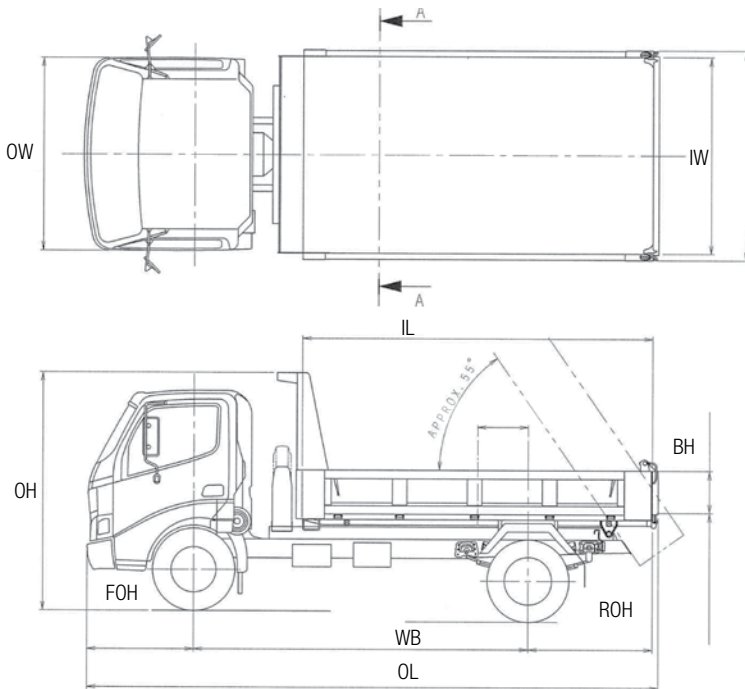
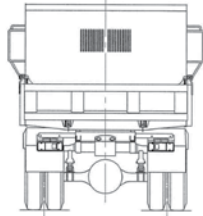

DIMENSIONS - mm / Capacities

Product code	XZU417R-HKFQDQ3 Dump
Model	716 Dump
Wheelbase (WB)	3430
Overall length (OL)	5780
Overall width (OW)	2130
Overall height (OH)	2375
Front overhang (FOH)	1045
Rear overhang (ROH)	1260
Inside body length (IL)	3600
Inside body width	2000
Body side height (BH)	430
Road clearance	200
Turning circle - m (kerb-to-kerb)	11.4
Turning circle - m (wall-to-wall)	12.8
Fuel tank – lt.	100
Chassis mass – kg (minimal fuel, without a spare tyre or tools)	
Total	3345kg
Front	1835kg
Rear	1510kg
GVM	6500
GCM	10,000

DEALERSHIP

WARRANTIES

New vehicle warranty period

Light Duty Model	Axle configuration	Standard warranty <small>(whichever comes first)</small>	Cab corrosion perforation
300 716 Dump	4 x 2	3 years or 100,00km	36 months

Battery warranty is 12 months from date of delivery.

DISCLAIMER

Important notice. Hino Trucks are distributed in Australia by Hino Motor Sales Australia Pty Ltd A.C.N. 064 989 724. Information contained in this brochure was correct at time of printing. Hino Motor Sales Australia Pty Ltd reserves the right to alter any details of the specifications and equipment without notice. Hino in so far as it is permitted by law to do so, shall not be liable in any way as a result of any reliance placed by any person on anything contained in this brochure. You should therefore check with your authorised Hino dealer at the time of ordering your motor vehicle to ensure that colour, specifications, equipment, design features and options are available for the vehicle you are ordering. Please note that some options may only be available in combination with others. Authorised Hino dealers will on request provide up to date information on all accessories, design features, prices and availability.

Date of issue 14/02/08 716 Dump V-3