

FREIGHTER



Drop Deck Semi-Trailer

The Freighter Advantages

For more than 50 years, Freighter has designed and engineered the industry's most reliable and innovative road transport trailers, providing its customers with leading edge logistics solutions that deliver maximum payload and maximum versatility.

Freighter's drop deck semi-trailer, available either in single trailer, lead and tag B-Double or road train configurations, features enhanced stability and safety through its wide spaced main beams and wide track axles, with low profile frames that deliver a lower centre of gravity.

The Freighter drop deck semi is available either as a 22 pallet or 24 pallet trailer and options such as an extendible configuration and beaver tail/ramp configurations deliver maximum operational flexibility.

The integrity of Freighter engineering allows for minimum tare weight and maximum payload with advanced styling and component design

giving you the quality appearance and performance you have come to expect from Freighter.

LED lights are standard and allow operation at either 12 or 24 volt, for simple truck changes.

The Freighter Options to suit your needs

- Beaver Tail / Ramp Configuration
- Extendible Configuration
- Container Twistlocks
- Folding Twistlock Pedestals
- Disc Brakes
- 8⁵/₈" heavy duty drum brakes (with Intraax)
- Alloy Wheels
- Lightweight alloy gates or galvanised steel
- Hub odometer
- Extra toolboxes
- Water Tank(s)
- Heavy Duty option available



FREIGHTER

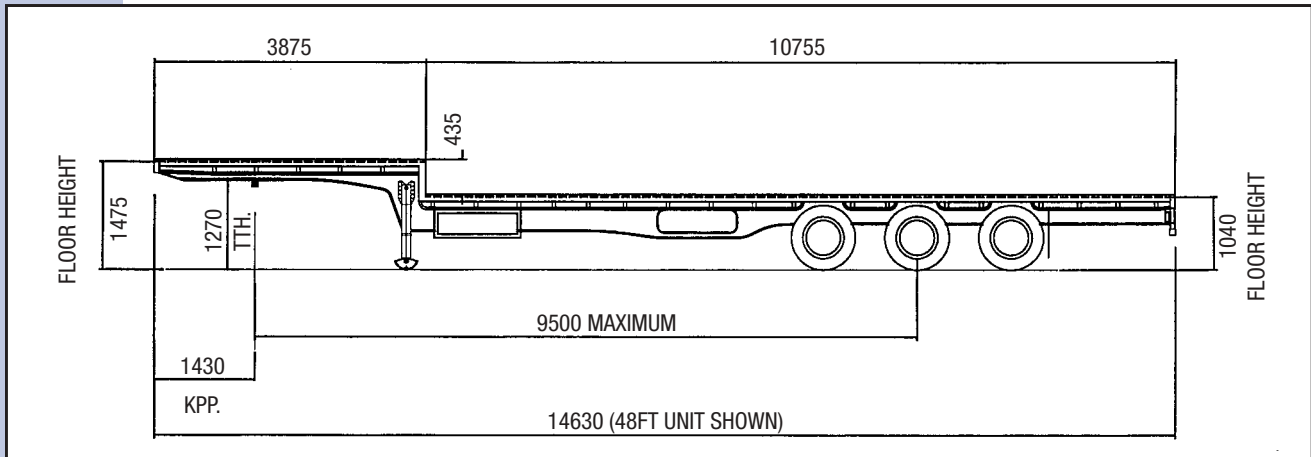

Drop Deck Semi-Trailer Specifications (Nominal)



First Class Paint Quality
MaxiTRANS' new paint process starts with a thorough grit blast, followed by a three stage, oven baked paint with high quality primer and two pack finish coat.



Beaver Tail and Ramp
Beaver tail and ramp allow fast, convenient access to trailer deck for drive-on drive-off loading.



Superior Chassis Design
Developed through a computer-aided design process, Freighter's chassis delivers optimum strength and durability for long life in Australian conditions with lowest possible contribution to tare weight.



Improved Lighting
LED lights improve safety and combine long life and reliability with lower operating costs.

Dimensions

Length	13730mm / 14630mm (45/48ft)
Skidplate Height	1270mm
Kingpin Location	1430mm from front
Suspension Location	9500mm from kingpin
Drop Height	435mm

Frame

Bumper	Square
Skidplate	8mm with 50mm bolt-in kingpin
Base Frame	1040mm mainrail centres 12mm top flange. 16mm bottom flange
Floor	3mm steel checkerplate – fully welded
Coaming	100 x 45 R.S.J. (Raised 23mm)

Suspension

Hendrickson HT250U tri-axle air bag underslung
Optional Hendrickson Intraax Low Ride

Brakes

420 x 178mm (16.5" x 7") S' Cam to A.D.R. 38.
Bonded Linings PBR male and female couplings at front.

Axles

Freighter Maxus II – 16mm wall. 5-spoke spider, dual rim, grease lubricated hubs.

Underbody

Toolbox	1 standard dropframe. Kerbside.
Tyre Carrier	Integral. 2 Wheel.

Load Restraint

Tie Rails	25mm NB Pipe both sides
Load Racks	1525mm high (Front) 1985mm High (Rear) – white enamel
Coaming Pockets	To suit 6 gates per side

Electrical

Voltage	Multi-volt to A.D.R. 13
Lamps	LED Multi-volt

Landing Gear

Rocker Foot	2 speed
-------------	---------

Paint

1 colour 2K	Coamings, toolbox & hubs
Underside	Silver

Mudguards

Extruded aluminium splashguards with sprayguard flaps fitted to rear of suspension group.

Legendary Freighter finish, long-term performance & support

- Detailed, uncompromising pre-delivery inspections
- National warranty, parts and service network
- Computer designed chassis delivers optimum strength and durability
- All steel components designed and manufactured in-house
- Use of highest quality components and genuine plan of continuous improvement
- Custom manufacturing also delivers special customised configurations for individual requirements – just ask your local Freighter dealer



Check out the demo models and deals at these Freighter Dealers. www.maxitrans.com.au

MaxiTRANS Aust Pty Ltd

Victoria (03) 8368 1111

Mildura Truck Centre

Sunraysia (03) 5021 2122

SX Trailers

NSW (02) 9755 3333

CMV Trailer Sales

SA (08) 8268 4422

New Zealand

Auckland (09) 267 5714

Freighter Maxi-CUBE QLD

Qld (07) 3277 5511

Roadwest Transport

WA (08) 9272 4111

Disclaimer: MaxiTRANS provides the information contained herein in good faith, based upon information current to date. MaxiTRANS reserves the right to change specifications without notice. However MaxiTRANS accepts no liability, either direct or indirect for any loss or consequential loss that may result from the application of this information. Purchasers must conduct their own enquiries to ensure that the products are suitable for their own particular purposes. Any comments made regarding products and construction are made on an informative basis, not as a recommendation. Some features shown may be optional. Conditions apply to MaxiTRANS Finance. ©Freighter, Maxi-CUBE, T Liner and MaxiTRAAX are registered to the MaxiTRANS Group. MaxiTRANS Australia Pty. Ltd. ABN 95 081 151 699