

Specification sheet



A **PACCAR** COMPANY

FAT CF75

6x4 Rigid

Engines

CF75.250; 183 kW
CF75.310; 228 kW
CF75.360; 265 kW

GVM¹⁾

24600 kg

Max. front³⁾: 6500 kg
Max. rear: 18100 kg

GCM²⁾

38000 kg



	Wheelbase - AE		Unladen weight ⁴⁾			Gross Carrying Capacity			Variable dimensions									
	WB	AE ³⁾	Front	Rear	Total	Front	Rear	Total	AC	CB ⁶⁾	CH ⁷⁾	BL ⁸⁾	BL ⁸⁾	TL	HA ⁹⁾	HA ¹⁰⁾	TK ¹¹⁾	TW ¹²⁾
Day	4.55	2.00	4500	3200	7700	2000	14900	16900	0.39	0.24	1.86	6.60	6.60	7.93	1.01	0.99	15.26	16.75
	6.00	3.60	4510	3490	8000	1990	14610	16600	0.39	0.24	1.86	8.90	8.90	10.98	1.01	0.99	19.04	20.58
Sleeper	4.55	2.00	4595	3200	7795	1905	14900	16805	0.82	0.24	1.86	6.10	6.20	7.93	1.01	0.99	15.26	16.75
	6.00	3.60	4605	3480	8085	1895	14620	16515	0.82	0.24	1.86	8.50	8.50	10.98	1.01	0.99	19.04	20.58

Other dimensions VA: 1.38 WT:1.37 HV¹³⁾:0.97 HV¹⁴⁾:0.90 RB:0.86 SB: 1.82 TB: 2.44

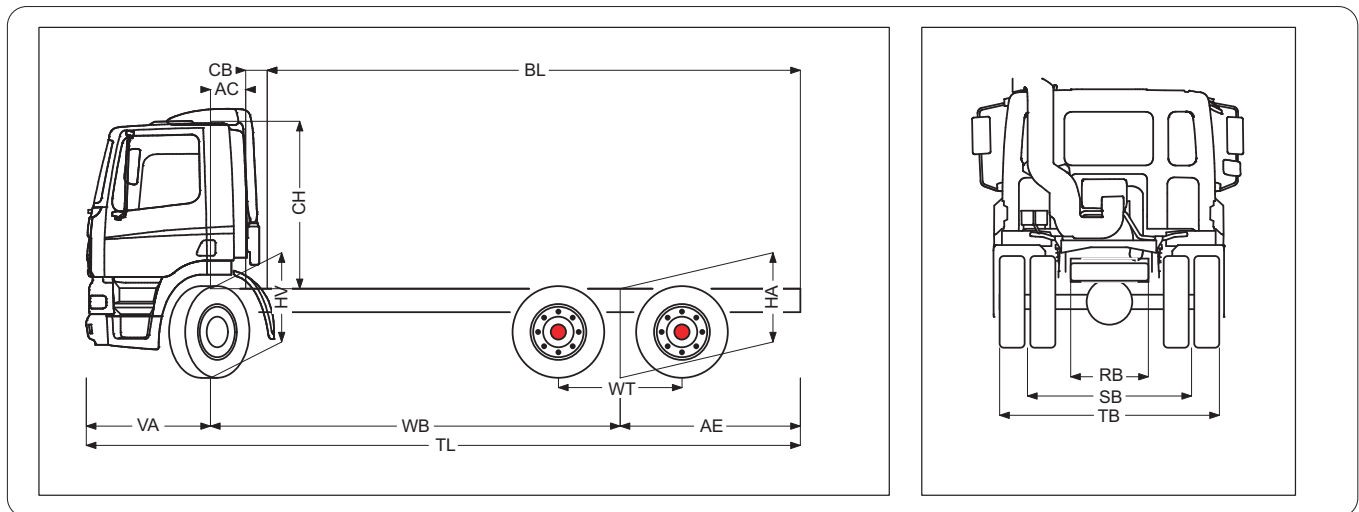

- 1) GVM in conformity with registration documents.
- 2) GCM in conformity with registration documents.
- 3) Axle load with standard tyre size.
- 4) Chassis and Cab Weight calculated with: Standard specification items and empty fuel tank. With Sleeper Cab; + 105 kg at front; Roof kit with extenders +73kg.
- 5) Cab height is measured from frame member to closed cabin roof hatch. With air intake on cab roof: +0.14m.
- 6) CB is based on standard air intake and/or exhaust.
- 7) Cab height is measured from frame member to closed cabin roof hatch. With air intake on cab roof: +0.14m
- 8) Calculate customer specific body length with TOPEC
- 9) Unladen height at centre of rear axle(s).
- 10) Laden height at centre of rear axle(s).
- 11) TK = turning circle between kerbs (For comparison purposes only).
- 12) TW = turning circle between walls (For comparison purposes only).
- 13) Unladen height at centre of front axle(s).
- 14) Laden height at centre of front axle(s).

FAT CF75

ENGINE

PACCAR	6 cylinder, turbo intercooled
Piston displacement	9.2 litres
Compression ratio	17.4 to 1
Fuel injection	Electronically controlled
Type	PR 228
Max output	228kW / 310hp at 2200 rpm
Max torque	1275Nm at 1200-1700 rpm
Options:	
- Type	PR 183
Max output	183kW / 250hp at 2200 rpm
Max torque	1050Nm at 1100-1700rpm
- Type	PR 265
Max output	265kW / 360hp at 2200 rpm
Max torque	1450Nm at 1200-1700 rpm

CHASSIS

Completely flat-topped chassis frame; Riveted and bolted construction of channel-section main frame members and cross members; 1 x 430 litre aluminium fuel tank; Fuel tank height – 620 mm; 1x45 litre Adblue tank; Horizontal box type exhaust silencer at RHS with vertical pipe; Side marker lamps; Dimensions main frame members: 260 x 75 x 7 or 310 x 75 x 7 mm with inner reinforcement; 4.55m wheelbase; Spray suppression behind steer tyre; Front underrun protection system (FUPS).

Options:

- 6.00m wheelbase
- Spare wheel carrier with spare wheel (only with 6.00m wheelbase and single fuel tank)
- 340 litre aluminium fuel tank
- 2 x 430 litre aluminium fuel tanks

GEARBOX

16S1800: ZF synchro 4-speed main gearbox with range-change group and splitter group, giving 16 speeds.

Options:

- 12AS1930: ZF 12 speed, automated manual, ZF AS Tronic transmission

	PR 183	PR 228	PR 265
16S1800-11.54/0.84	X	X	X
12AS1930-12.33/0.78	X	X	X

CLUTCH

Single type, pushed operation, asbestos free, dry plate, hydraulically operated and pneumatically assisted, electronically operated on AS Tronic

Diameter: 430mm

FRONT AXLE

Type: 152N
Max. design load: 7500 kg
I-section axle. Stub axles with needle bearings.

REAR AXLE

Type: Meritor MT21-144
Max. design load: 18100 kg
Double drive tandem axle with spiral bevel gearing; Lockable inter axle, and axle differentials.
Ratio: 3.91

FRONT SUSPENSION

Parabolic type leaf springs with shackled ends at rear – maintenance free; Shock absorbers and stabiliser bar.
Spring dimensions: 1x1800x80x31 + 1x1800x80x32 mm (7500 kg)

REAR SUSPENSION

Airglide 200 8 bag air suspension with shock absorbers and stabiliser bars; Aluminium pedestals.
Max. design load: 18100 kg

WHEELS AND TYRES

22.5" (10 stud 335 PCD) Silver steel disc wheels with 295 / 80 R 22.5 tubeless radial tyres at front and dual 11 R22.5 tyres at rear.

Options:

- Alcoa polished wheels
- Wheel protection rings
- Alcoa aluminium satin disc wheels

STEERING

Type: Hydraulic power steering with adjustable steering column for rake and height.

BRAKE SYSTEM

Dual circuit air operated drum brakes on rear axles with automatic slack adjusters; Front axle air operated disc brakes with wear indicator on instrument panel.

Disc Brake dimensions: 430 x 45 mm
Drum Brake dimensions: 420 x 180 mm

EBS (Electronic Braking System incorporating ABS); Emergency/parking brake with spring brake actuators on rear axles; Exhaust brake (retardation power 170kW at 2800rpm); ASR (Acceleration Slip Control).

Options:

- ZF interarder (retardation power 420kW)

ELECTRICAL EQUIPMENT

Voltage:	24 V
Alternator:	80 A
Batteries:	2 x 175 Ah
Starter Motor:	24 V
Rear light units:	Incorporating direction indicator light, stop light, reversing light, side marker light and reflector; Main switch with manual control located near the battery box; Reverse warning alarm.

TRAILER EQUIPMENT

Trailer brake connectors:	2-line to rear of chassis
Trailer light connectors:	24V

CAB EXTERIOR

F230 tilt Day Cab with 4 coil spring suspension and hydraulic tilting device; Tilting angle 57.5°; Fixed, illuminated cab steps; Manually controlled roof hatch; Heated and electrically adjustable main and wide angle mirrors; Steel front bumper with foot hold; Combi lights, incorporating driving and fog lights in lower bumper; External sun visor; Corner air deflectors; Side collars; Rear window.

Options:

- Sleeper cab
- Space cab
- Side window
- Air horns (single and dual set)
- Adjustable roof spoiler
- Remote hatch control (Space cab only)

COLOURS

Cab colour:	M8870 Ice White
Chassis colour:	Black
Mirror cover:	Black
Bumper colour:	Grey

Options:

- Mirror covers cab colour
- Bumper cab colour
- Various non-standard and metallic cab and chassis colours, see colour guide or dealermet

CAB INTERIOR

High quality trim and upholstery in natural camel-grey colour; Cab floor cover includes easy-clean top layer in camel-grey; Cockpit style dashboard, including DIP (driver information panel) and Adblue indicator; Adjustable luxury air suspended driver seat and fixed co-driver seat with head restraint; Various storage facilities including two cup holders, containers behind seat and overhead compartments; 4 spoke, soft grip steering wheel with integrated control switches; Electric window openers (driver and passenger); Cruise control; Personal road speed limiter; Black dashboard finish; Integrated 3-point seat belt; Air conditioning; Radio/CD/MP3 player with 2 speakers; Antennas: 1 x GSM; Remote control door lock.

Options:

- Hands free telephone kit
- Passenger luxury air seat
- 3rd seat (day cab only)
- Driver's seat arm rest (only with AS Tronic)
- Leather finish steering wheel
- Wood structure dashboard finish
- Automatic temperature control
- Additional upper bunk (only with space cab)
- Lane departure warning signal
- FMS connector prepared (Fleet Management System)
- Refrigerator (not available with day cab or rear window)
- Bunk with sleeper cab (height depending on refrigerator and storage boxes)
- SRS drivers air bag with seat belt pretensioner on driver and passenger seats

POWER TAKE OFF (PTO)

Engine speed control connector; PTO prepared.

Options:

- Various types of PTOs / position combinations – refer DTA

LEGAL ASPECTS

- Exhaust Emission Euro 4
- ECE R29 Cab Certification
- ADR 83 Noise Certification
- Front Underrun Protection Certification

APPLICATION CONDITIONS

Air intake with cyclonic pre-filter behind the cab, Standard tool kit; Fuel water separator.

MAX. SPEED

All vehicles are speed limited to 100km/h.

Depending on the vehicle configuration a specific option may not be possible. All weights and measurements should be regarded as approximate only. In the interests of product improvements, DAF Trucks Australia reserve the right to change these specifications without prior notice. For further information please contact DAF Trucks Australia.