

Specification sheet



A **PACCAR** COMPANY

FT CF75

4x2 Prime Mover



Engines

CF75.250; 183 kW
CF75.310; 228 kW
CF75.360; 265 kW

GVM¹⁾

17400 kg
Max. front³⁾: 6500 kg
Max. rear: 10900 kg

GCM²⁾

38000 kg

	Wheelbase - AE		Unladen weight ⁴⁾			Gross Carrying Capacity			Variable dimensions									
	WB	AE	Front	Rear	Total	Front	Rear	Total	AC	CE	CH ⁵⁾	KA ⁶⁾	TL	HA ⁷⁾	HA ⁸⁾	TK ⁹⁾	TW ¹⁰⁾	
Day	3.25	0.84	4365	1805	6170	1635	7195	8830	0.39	3.70	1.86	0.70	5.47	0.99	0.96	11.91	13.32	
	3.60	0.99	4370	1850	6220	1630	7150	8780	0.39	4.20	1.86	0.57	5.97	0.99	0.97	12.81	14.24	
	3.80	0.99	4380	1830	6210	1620	7170	8790	0.39	4.40	1.86	0.83	6.17	0.99	0.96	13.33	14.77	
Sleeper	3.25	0.84	4460	1805	6265	1540	7195	8735	0.82	3.27	1.86	0.68	5.47	0.99	0.96	11.91	13.32	
	3.60	0.99	4465	1850	6315	1535	7150	8685	0.82	3.77	1.86	0.76	5.97	0.99	0.96	12.81	14.42	
	3.80	0.99	4475	1830	6305	1525	7170	8695	0.82	3.97	1.86	0.80	6.17	0.99	0.96	13.33	14.77	

Other dimensions VA: 1.38 HV¹¹⁾:0.97 HV¹²⁾:0.94 RB:0.97 SB: 1.82 TB: 2.44 CB: 0.24

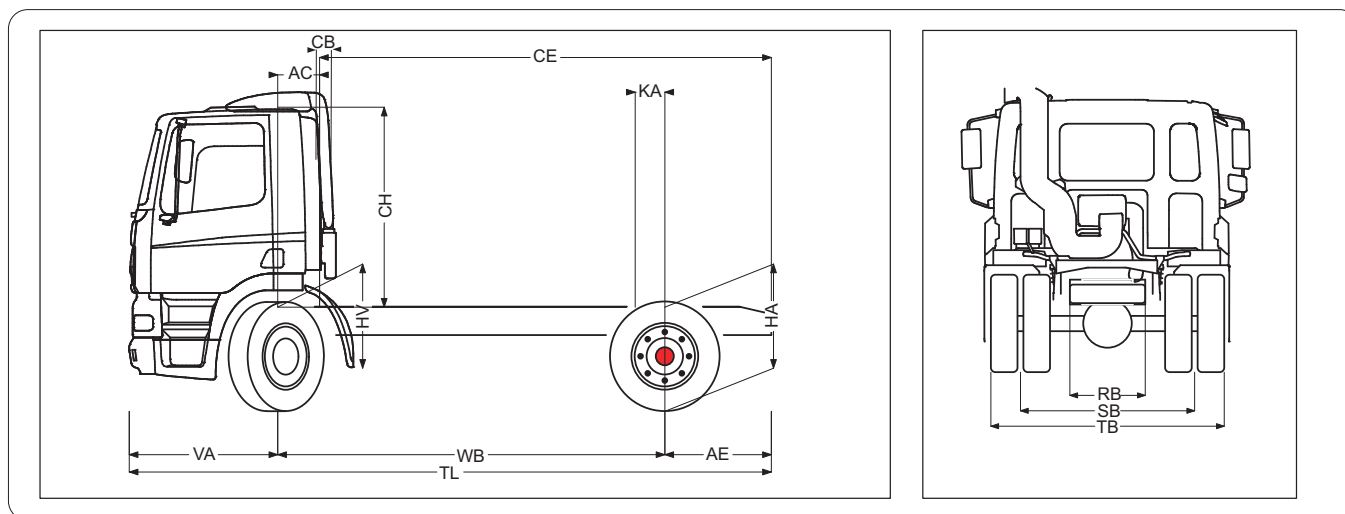

- GVM in conformity with registration documents.
- GCM in conformity with registration documents.
- Axle load with standard tyre size.
- Chassis and Cab Weight calculated with: Standard specification items and empty fuel tank. With Sleeper Cab; + 105 kg at front; Roof kit with extenders +73kg.
- Cab height is measured from frame member to closed cabin roof hatch. With air intake on cab roof: +0.14m.
- Calculate customer specific KA with TOPEC.
- Unladen height at centre of driven axle(s).
- Laden height at centre of driven axle(s).
- TK = turning circle between kerbs (For comparison purposes only).
- TW = turning circle between walls (For comparison purposes only).
- Unladen height at centre of front axle(s).
- Laden height at centre of front axle(s).
- CB is based on standard intake and/or exhaust.

FT CF75

ENGINE

PACCAR	6 cylinder, turbo intercooled
Piston displacement	9.2 litres
Compression ratio	17.4 to 1
Fuel injection	Electronically controlled
Type	PR 228
Max output	228kW / 310hp at 2200 rpm
Max torque	1275Nm at 1200-1700 rpm
Options:	
- Type	PR 183
Max output	183kW / 250hp at 2200 rpm
Max torque	1050Nm at 1100-1700rpm
- Type	PR 265
Max output	265kW / 360hp at 2200 rpm
Max torque	1450Nm at 1200-1700 rpm

CHASSIS

Completely flat topped chassis frame; Riveted and bolted construction of channel-section main frame members (tapered at the rear end) and cross members; 1x430 litre aluminium fuel tank; Fuel tank height – 620 mm; 1x75 litre Adblue tank (50 litre with spare wheel carrier); Horizontal box type silencer at RHS with vertical pipe; Spray suppression behind steer tyre; Front underrun protection system (FUPS); Catwalk and step; Main frame members with angle sections for mounting of fifth wheel at 50mm even spacing; 3.6m wheelbase.

Dimensions main frame members: 260 x 75 x 6 mm or 260 x 75 x 7 mm with front inner reinforcement.

Options:

- 340 litre aluminium fuel tank - 1 x 340 and 1 x 430 litre aluminium fuel tanks
- Spare wheel carrier with spare wheel (only with 1 fuel tank) - 1 x 750 and 1 x 430 litre aluminium fuel tanks (not with 3.25m wheelbase)
- Wheelbase – 3.25m, 3.8m

GEARBOX

16S1800: ZF synchro 4-speed main gearbox with range-change group and splitter group, giving 16 speeds.

Options:

- 12AS1630: ZF 12 speed, automated manual, ZF AS Tronic transmission
- 16S1600: ZF synchro 4-speed main gearbox with range-change group and splitter group, giving 16 speeds
- 12A1420: ZF 12 speed, automated manual, ZF AS Tronic transmission

	PR 183	PR 228	PR 265
16S1600-16.41/1.00	X	X	X
12AS1630-15.86/1.00	X	X	X
16S1800-15.8/0.84	X	X	-
12AS1420-10.37/0.81	X	X	-

CLUTCH

Single type, pushed operation, asbestos free, dry plate, hydraulically operated and pneumatically assisted, electronically operated on AS Tronic.

Diameter: 430mm

FRONT AXLE

Type: 152N
Max. design load: 7500 kg
I-section axle. Stub axles with needle bearings.

REAR AXLE

Type: SR 1339 (SR1347 with PR265 engine)
Max. design load: 13000 kg
Single reduction driven axle with diff lock.
Ratio: 3.73

FRONT SUSPENSION

Parabolic type leaf springs with shackled ends at rear – maintenance free; Shock absorbers and stabiliser bar.

Spring dimensions: 1x1800x80x28 + 1x1800x80x31 mm (7500 kg)

REAR SUSPENSION

DAF 4 bag ECAS (Electronically Controlled Air Suspension); Shock absorbers and stabilizer bar; Axle load monitoring.

Max. design load: 13000 kg

WHEELS AND TYRES

22.5" (10 stud 335 PCD) Silver steel disc wheels with 295 / 80 R 22.5 tubeless radial tyres at front and dual 11 R22.5 tyres at rear.

Options:

- Alcoa polished wheels - Alcoa aluminium satin disc wheels
- Wheel protection rings

STEERING

Type: Hydraulic power steering with adjustable steering column for rake and height.

BRAKE SYSTEM

Dual circuit air operated disc brakes with wear indicators at front and rear

Brake dimensions: 430 x 45 mm

EBS (Electronic Braking System incorporating ABS); Emergency/parking brake with spring brake actuators on rear axles; Exhaust brake (retardation power 170kW at 2800rpm); ASR (Acceleration Slip Control).

Options:

- Vehicle stability control - ZF intarder (retardation power 420kW)

ELECTRICAL EQUIPMENT

Voltage: 24 V
Alternator: 80 A
Batteries: 2 x 175 Ah
Starter Motor: 24 V
Rear light units: Incorporating direction indicator light, stop light, reversing light, side marker light and reflector mounted on c-channel; Main switch with manual control located near the battery box; Reverse warning alarm.

TRAILER EQUIPMENT

Semi trailer brake connectors: 2-line with suzi couplings
5-pole (12V) connector for ABS
Semi trailer light connectors: Two 7-pole connectors (12 V, 24 V)
Adaptor: Voltage reducer: 24 V – 12 V

CAB EXTERIOR

F230 tilt Day Cab with 4 coil spring suspension and hydraulic tilting device; Tilting angle 57.5°; Fixed, illuminated cab steps; Manually controlled roof hatch; Heated and electrically adjustable main and wide angle mirrors; Steel front bumper with foot hold; Combi lights, incorporating driving and fog lights in lower bumper; Rear worklamp; External sun visor; Corner air deflectors; Side collars; Rear window.

Options:

- Sleeper cab - Space cab
- Side window - Air horns (single and dual set)
- Adjustable roof spoiler - Remote hatch control (Space cab only)

COLOURS

Cab colour: M8870 Ice White
Chassis colour: Black
Mirror cover: Black
Bumper colour: Grey

Options:

- Mirror covers cab colour - Bumper cab colour
- Various non-standard and metallic cab and chassis colours, see colour guide or delemat

CAB INTERIOR

High quality trim and upholstery in natural camel-grey colour; Cab floor cover includes easy-clean top layer in camel-grey; Cockpit style dashboard, including DIP (driver information panel) and Adblue indicator; Adjustable luxury air suspended driver seat and fixed co-driver seat with head restraint; Various storage facilities including two cup holders, containers behind seat and overhead compartments; 4 spoke, soft grip steering wheel with integrated control switches; Electric window openers (driver and passenger); Cruise control; Personal road speed limiter; Black dashboard finish; Integrated 3-point seat belt; Air conditioning; Radio/CD/MP3 player with 2 speakers; Antennas: 1 x GSM; Remote control door lock.

Options:

- Hands free telephone kit - Passenger luxury air seat
- 3rd seat (day cab only) - Driver's seat arm rest (only with AS Tronic)
- Leather finish steering wheel - Wood structure dashboard finish
- Automatic temperature control - Lane departure warning signal
- Additional upper bunk (only with space cab) - FMS connector prepared (Fleet Management System)
- Bunk with sleeper cab (height depending on refrigerator and storage boxes)
- SRS drivers air bag with seat belt pretensioner on driver and passenger seats
- Refrigerator (not available with day cab or rear window)

POWER TAKE OFF (PTO)

Engine speed control connector; PTO prepared.

Options:

- Various types of PTOs / position combinations – refer DTA

LEGAL ASPECTS

- Exhaust Emission Euro 4 - ECE R29 Cab Certification
- ADR 83 Noise Certification - Front Underrun Protection Certification

APPLICATION CONDITIONS

Air intake with cyclonic pre-filter behind the cab; Standard tool kit; Fuel water separator.

MAX. SPEED

All vehicles are speed limited to 100km/h.

Depending on the vehicle configuration a specific option may not be possible. All weights and measurements should be regarded as approximate only. In the interests of product improvements, DAF Trucks Australis reserve the right to change these specifications without prior notice. For further information please contact DAF Trucks Australia.