

MK6_{AUTO}

Leaf Suspension

GVM 10,400kg* GCM 10,400kg**

Specifications



ENGINE

Model: J08 -TE - a vander engine manufactured for Nissan Diesel
6 cylinder 4 valves per cylinder, 4 cycle, direct injection, water cooled, in-line diesel engine, Variable nozzle turbocharger with intercooler

Number of cylinders: 6 cylinders
Bore x stroke: 112mm x 130mm
Total piston displacement: 7,684 cc
Max. output (ISO Net): 168 kw (228 PS) at 2,500 rpm
Max. torque (ISO Net): 686 N.m (70 kgm) at 1,500 rpm
Max. governed speed: 2,550 rpm
Compression ratio: 18:1
Auxiliary brake: Pneumatically operated Exhaust brake

Lubrication System:

Forced feed by gear pump, Flat tube type oil cooler, Full flow and by-pass oil filter with replaceable element, 11 litre capacity

Air compressor:

Water cooled reciprocating type, single cylinder with air dryer

Cooling System:

Forced feed by centrifugal water pump, wax pellet type thermostats incorporated with a by-pass, aluminium corrugate fin type radiator with reserve tank and viscous coupling driven 620mm 8 blade cooling fan.

FUEL AND INTAKE SYSTEM

High pressure electronically controlled common rail fuel injection system
Replaceable primary and secondary fuel filters
200lt capacity steel fuel tank with lockable cap (LHS)
Dry paper element air cleaner
High mounted RHS air intake snorkel

EXHAUST AND EMISSION CONTROL SYSTEM

Emission standard - ADR 80/02
Electronic controlled, selective, cooled EGR
Under chassis mounted RHS muffler / catalytic converter with horizontal rear facing exhaust discharge under truck

ELECTRICAL

24 volt, negative ground system
2 x 12 volt 120 Ah batteries mounted on frame side
24 volt - 90amp with built-in IC regulator

TORQUE CONVERTOR

Make and Model: ALLISON TC 221
One stage, three element, polyphase. Includes standard integral damper with lock up option
Stall torque ratio: 1.73 : 1

TRANSMISSION

Make and model: ALLISON LCT2500
Five forward speeds and one reverse. Fully automatic ALLISON Gen4 adaptive shift transmission with radiator mounted (water to oil) oil cooler.

Gear ratios:	Gear	Ratio	Gear	Ratio
	1st	3.51	4th	1.00
	2nd	1.90	5th	0.74
	3rd	1.44	Rev	5.09

Transmission PTO openings: LHS and RHS

PTO drive gear rating: 339Nm - Independent operation
271Nm - Dual operation
Torque rating @ 1:1 Turbine speed

BRAKES

Air Over Hydraulic (AOH) dual line, internal expanding, leading / trailing shoe type system with 4 channel BOSCH ABS

Air pressure: 7.2 - 8.5 kg/cm²

	Front	Rear	Total
Drum diameter:	320 mm	320 mm	
Lining area:	1360 cm ²	1672 cm ²	3032 cm ²

Hand operated pneumatically controlled spring park brake acting on drive axle.

STEERING

Recirculating ball screw type steering box with hydraulic power assist Adjustable, tilt and telescopic type column with steering lock and 460mm wheel

Variable steering gear ratio: Between 18.8 : 1 and 16.1 : 1

WHEELS AND TYRES

Number and size of tyre:	Front	Rear
Front - single	235/75R 17.5 132/130M	
Rear - dual		235/75R 17.5 132/130M

Pressed steel disc wheel, 1 piece rim, 6.75 x 17.5 131 offset-10TCS, 6 stud
One spare wheel and tyre mounted on carrier (STC) at the rear of chassis

AXLES

FRONT **NISSAN DIESEL FA35**
Drop forged steel "I" section beam, reverse "ELLIOT" type
Front axle capacity: 3,700 kg *Refer to Load Rating summary for max permissible load

REAR **NISSAN DIESEL RS55**
Fully floating pressed steel banjo type housing, in-line tandem type
Final reduction gear: Single reduction, hypoid gear
Final reduction gear ratio: 4.111
Rear axle capacity: 7,500 kg *Refer to Load Rating summary for max permissible load

SUSPENSION

FRONT
Taper leaf spring with anchor at front and shackle at rear
Width x length: 70 x 1,300 mm
The number of leaves: 3
Spring constant: 264N/mm (26.9 kg/mm)
Shock absorbers: Telescopic double acting

REAR
Semi-elliptic leaf spring and helper with anchor at front and shackle rear
Width x length: Main: 70 x 1300mm Helper: 70 x 980mm
The number of leaves: Main: 7 Helper: 7
Spring constant (Total): 985 N/mm (100.4 kg/mm)
Shock absorbers: Telescopic double acting

LOAD CAPACITY SUMMARY

	Front (kg)	Rear(kg)
Axle capacity	3700	7500
Steering / Suspension Capacity	3700	7500
Tyre capacity	4000	7600
Max capacity (limit kg)	3700	7500

Note: Based on 235/75R 17.5 front and rear tyres and standard springs

MK6 AUTO Leaf Suspension

CAB

Forward control, spring suspended cab with shock absorbers
Torsion bar cab tilt system
Front opening inspection panel
Air dam front bumper
Dash design integrates an array of instruments, warning / informational lights and audible tones

Standard Equipment

Overhead console with driver and passenger sunvisors
24v Cigarette lighter / power supply with 2 ash trays
Large On/Off/Door interior light
Double arm, 2-spd wipers with intermittent operation
Windscreen washers
LH and RH split mirrors (Flat / spot)
LH down spot mirror
Electric horn, reverse warning light and alarm
3 occupant seats - 2 outer seats with retractable seat belts and a flat folding centre seat with adjustable lap belt.
Multi adjustable air suspended driver's seat
ADR42/04 compliant sleeper bunk with mattress (Stationary sleeping only)
Sleeper cab curtain rails with curtains
Power operated driver and passenger windows
Remote operated keyless central locking
Multi speed air conditioning
AM/FM radio with CD player
Cruise control - Stalk mounted
Halogen multi reflector headlamps

Front bumper mounted (ADR49/00) integrated driving lights
Roof mounted clearance lights (ADR49/00)
2 centre dashmounted cup holders
3 DIN sized compartments for accessory fitment

FRAME

Ladder, Channel type chassis construction

Width: 860mm

Height x width x thickness: 234 x 70 x 7 mm

Material: Pressed carbon steel

Tensile	Yield	Modulus
45kg/mm ²	30kg/mm ²	Refer body manual

FACTORY OPTIONAL EQUIPMENT (Indent order only)

Paint colours
Multi leaf front springs 244N / mm (24.9 kg/mm)
Front stabilizer bar
Large centre console (Replaces centre seat)
Electronic engine governor control
Electronic transmission PTO control
225/90R 17.5 tyres - (6.00 x 17.5-135mm offset 10TCS 6stud) - with 4.333
ADR64/00 100km/h speed limiter

Dealer options

Rear Engine PTO (225Nm @ 1:1 engine speed continuous operation)
Additional transmission oil cooler for heavy duty application (Compactor / sweeper / etc)

PERFORMANCE (Calculated)

	4.111 with 235/75R 17.5	4.333 with 225/90R 17.5
Max. speed:	N/A	N/A
Gradeability 1st gear (Calculated):	TBA	TBA
Gradeability 5th gear (Calculated):	4% @ 10,400kg	3.8% @ 10,400kg
Est. RPM @ 100km/h:	2119rpm	2298rpm

GENERAL SPECIFICATIONS (approx.)

Wheel Base	Weight (kg)				
	GVM	GCM	FA	RA	Total Tare
E	10400	10400	2290	1170	3460
F	10400	10400	2300	1180	3480
K	10400	10400	2320	1200	3520

Dimensions (mm)												
WB	OL	OW	OH ²	FT	RT	ROH	CA	GC ²	FHF ²	FHR ²	Turn Radius Kerb to Kerb	
3770	6665	2200	2475	1780	1675	1620	2740	185	720	850	5990	
4230	7335	2200	2475	1780	1675	1830	3200	185	720	850	6720	
4830	8235	2200	2475	1780	1675	2130	3800	185	720	850	7670	

Weight estimated including fluids (not fuel) and STC and spare wheel, excludes tools and driver.² Based on vehicle with standard 11R 22.5 front and rear tyres. Subtract 42mm for 275 / 70R 22.5 tyres.

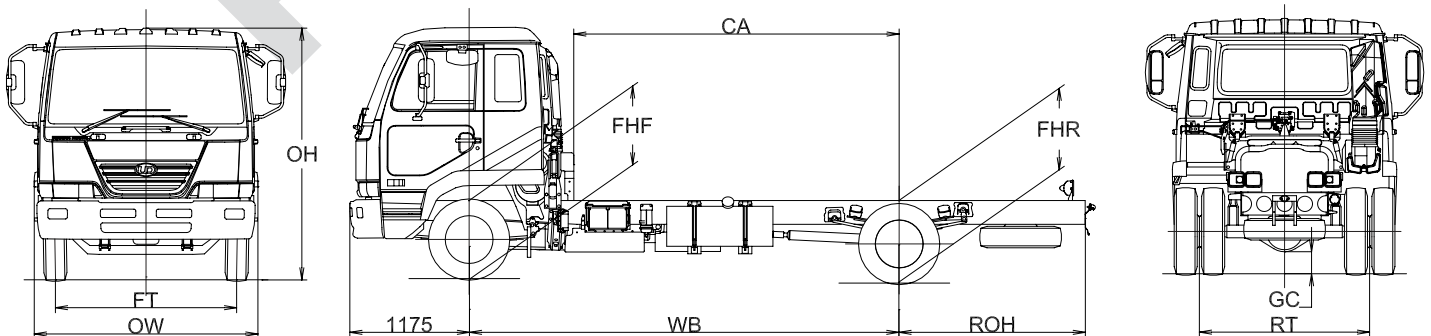

Imported and distributed by UD Trucks Australia Pty Ltd(A.C.N 085 417 376) Photos for illustration purposes. As part of continual product improvement the within specification are subject to change without notice. UDTA in as far as it is permitted by law to do so shall not be liable in any way as a result of any reliance placed by any persons or anything contained in this document. Please consult with UDTA dealer for the latest information about vehicle specifications.

*Rated GVM and axle capacities are subject to federal, state and Territory legal requirements. ** Higher GCM on engineering application, see your dealer.

