

MK6 PLUS

Leaf Suspension

GVM 10,400kg* GCM 14,900kg



Specifications

ENGINE

Model: **J08 -TB** - a vander engine manufactured for Nissan Diesel
6 cylinder 4 valves per cylinder, 4 cycle, direct injection, water cooled, in-line diesel engine, Variable nozzle turbocharger with intercooler

Number of cylinders: 6 cylinders
Bore x stroke: 112mm x 130mm
Total piston displacement: 7,684 cc
Max. output (ISO Net): 190 kw (258 PS) at 2,500 rpm
Max. torque (ISO Net): 794 N.m (81 kgm) at 1,500 rpm
Max. governed speed: 2,550 rpm
Compression ratio: 18:1
Auxiliary brake: Pneumatically operated Exhaust Brake

Lubrication System:

Forced feed by gear pump, Flat tube type oil cooler, Full flow and by-pass oil filter with replaceable element, 11 litre capacity

Air compressor:

Water cooled reciprocating type, single cylinder with dryer and oil mist separator

Cooling System:

Forced feed by centrifugal water pump, wax pellet type thermostats incorporated with a by-pass, aluminium corrugate fin type radiator with reserve tank and viscous coupling driven 620mm 8 blade cooling fan

FUEL AND INTAKE SYSTEM

High pressure electronically controlled common rail fuel injection system
Replaceable primary and secondary fuel filters
200lt capacity steel fuel tank with lockable cap (LHS)
Dry paper element air cleaner
High mounted RHS air intake snorkel

EXHAUST AND EMISSION CONTROL SYSTEM

Emission standard - ADR 80/02
Electronic controlled, selective, cooled EGR
Under chassis mounted RHS muffler / catalytic converter with horizontal rear facing exhaust discharge under truck

ELECTRICAL

24 volt, negative ground system
2 x 12 volt 120 Ah batteries mounted on LHS frame
24 volt - 60 amp. with built-in IC regulator

CLUTCH

Dry single plate, organic, hydraulically operated clutch release mechanism with air servo assistance

Diameter of clutch disc: 350 mm

TRANSMISSION

Make and model: **Nissan Diesel MPS63B**

Six forward speeds and one reverse, synchro mesh 2nd to 6th gears. Non-synchro 1st and reverse. Mechanical remote control operated shift with air servo assist

Gear ratios:	Gear	Ratio	Gear	Ratio
	1st	7.03	4th	1.50
	2nd	4.28	5th	1.00
	3rd	2.49	6th	0.78
			Rev	7.038

Transmission PTO opening: LHS

PTO drive gear rating: 300Nm @ 100% engine speed (nominal ratio)

BRAKES

Air Over Hydraulic (AOH) dual line, internal expanding, leading and trailing shoe type system with 4 channel BOSCH ABS and Easy Hill start (EHS)

Air pressure: 7.2 - 8.5 kg/cm²

	Front	Rear	Total
Drum diameter:	320 mm	320 mm	
Lining area:	1360 cm ²	1672 cm ²	3032 cm ²

Hand operated pneumatically controlled spring park brake acting on drive axle

STEERING

Recirculating ball screw type steering box with hydraulic power assist
Adjustable tilt and telescopic type column with steering lock and 460mm wheel

Variable steering gear ratio: Between 18.8 : 1 and 16.1 : 1

WHEELS AND TYRES

Number and size of tyre:	Front - single	235/75R 17.5 132/130M
	Rear - dual	235/75R 17.5 132/130M

See Options for alternative tyre size

Pressed steel disc wheel, 1 piece rim, 6.75 x 17.5 131 offset-10TCS, 6 stud
One spare wheel and tyre mounted on carrier (STC) at the rear of chassis

AXLES

FRONT

NISSAN DIESEL FA35

Drop forged steel "I" section beam, reverse "ELLIOT" type

Front axle capacity: 3,700 kg *Refer to Load Rating summary for max permissible load

REAR

NISSAN DIESEL RS55

Fully floating pressed steel banjo type housing, single drive type

Final reduction gear: Single reduction, hypoid gear

Final reduction gear ratio: 3.900

Rear axle capacity: 7,500 kg *Refer to Load Rating summary for max permissible load

SUSPENSION

FRONT

Taper leaf spring with anchor at front and shackle at rear

Width x length: 70 x 1,300 mm

The number of leaves: 3

Spring constant: 264N/mm (26.9 kg/mm)

Shock absorbers: Telescopic double acting

REAR

Semi-elliptic leaf spring and helper with anchor at front and shackle rear

Width x length: Main: 70 x 1300mm Helper: 70 x 980mm

The number of leaves: Main: 7 Helper: 7

Spring constant (Total): 985 N/mm (100.4 kg/mm)

Shock absorbers: Telescopic double acting

LOAD CAPACITY SUMMARY

	235/75R 17.5 tyres		225/90R 17.5 tyres	
	Front(kg)	Rear(kg)	Front(kg)	Rear(kg)
Axle capacity	3700	7500	3700	7500
Steering / Suspension Capacity	3600	7500	3600	7500
Tyre capacity	3700	7500	3600	6800
Max capacity (limit kg)*	3600	7500	3600	6800

Note: Based on nominated tyres and standard springs

MK6 PLUS Leaf Suspension

CAB

Forward control, spring suspended cab with shock absorbers
Torsion bar cab tilt system
Front opening inspection bonnet
Air dam front bumper

Standard Equipment

Overhead console with driver and passenger sunvisors
24v Cigarette lighter / power supply with 2 ash trays
Large On/Off/Door interior light
Double arm, 2-spd wipers with intermittent operation and windscreen washers
LH and RH split mirrors (Flat / Spot)
LH down spot mirror
Electric horn, reverse warning light and alarm
3 occupant seats - 2 outer seats with retractable seat belts and a flat folding centre seat with adjustable lap belt.
Multi adjustable air suspended driver's seat
ADR42/04 compliant sleeper bunk with mattress (Stationary sleeping only)
Sleeper cab curtain rails with curtains
Power operated driver and passenger windows
Remote operated keyless central locking
Multi speed air conditioning
AM/FM radio with CD player
Cruise control - Stalk mounted
Halogen multi reflector headlamps
Front bumper mounted (ADR49/00) integrated driving lights
Roof mounted clearance lights (ADR49/00)
2 centre dashmounted cup holders
3 DIN sized compartments for accessory fitment

FRAME

Ladder, Channel type chassis construction

Width: 860mm
Height x width x thickness: 234 x 70 x 7 mm
Material: Pressed carbon steel

Tensile	Yield	Modulus
45kg/mm ²	30kg/mm ²	Refer body manual

INSTRUMENTS

Dash design integrates an array of instruments, warning / informational lights and audible tones

FACTORY OPTIONAL EQUIPMENT (Indent order only)

Paint colours
Multi leaf front springs 244N / mm (24.9 kg/mm) – 3800kg Capacity
Front stabilizer bar
Large centre console (Replaces centre seat)
Electronic engine governor control
Electronic transmission PTO control
225/90R 17.5 tyres - (6.00 x 17.5 - 135mm offset 10TCS 6stud) with 4.111 diff
ADR65/00 100km/h speed limiter - Dealer fit Option
Rear Engine PTO (225Nm @ 100% engine speed continuous operation) - Dealer fit Option
Rear Engine PTO (343Nm @ 72% engine speed continuous operation) - Dealer fit Option

PERFORMANCE (Calculated)

Max. speed:

Gradeability 1st gear (Calculated):

Gradeability 6th gear (Calculated):

Est. RPM @ 100km/h:

3.900 diff ratio with 235/75R 17.5 tyres

N/A
50.7% @ 10,400kg
4.7% @ 10,400kg
2119rpm

4.111 diff ratio with 225/90R 17.5 tyres

N/A
55.0% @ 10,400kg
5.2% @ 10,400kg
2298rpm

GENERAL SPECIFICATIONS (approx.)

Wheel Base	Weight (kg)				
	GVM*	GCM	FA ¹	RA ¹	Total Tare ¹
L	10400	14900	2340	1300	3640

Dimensions (mm)											
WB	OL	OW	OH ²	FT	RT	ROH	CA	GC ²	FHF ²	FHR ²	Turn Radius Kerb to Kerb
5150	8775	2200	2515	1780	1675	2350	4120	185	730	850	8180

¹Weight estimated including fluids (not fuel) and STC and spare wheel, excludes tools and driver. ²Based on vehicle with standard 235/75R 17.5 front and rear tyres. Add 23mm for 225/90R17.5 tyres.

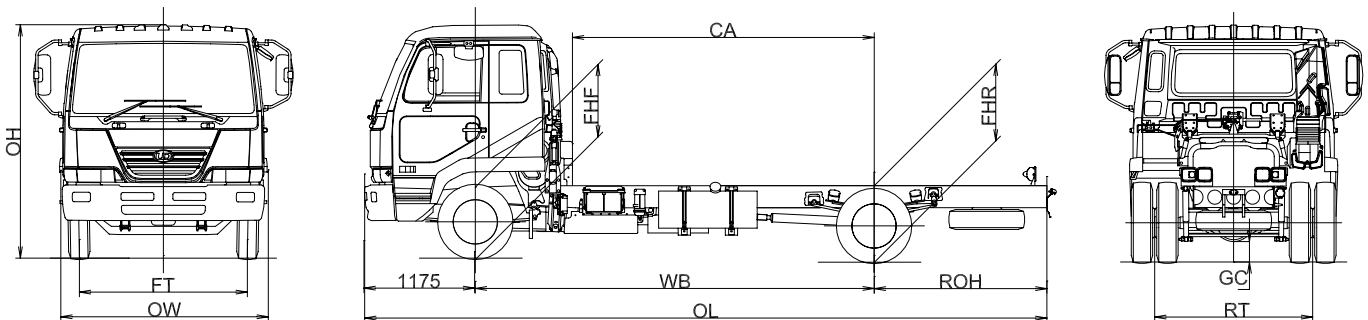

Imported and distributed by UD Trucks Australia Pty Ltd(A.C.N 085 417 376) Photos for illustration purposes.
As part of continual product improvement the within specification are subject to change without notice. UDTA in as far as it is permitted by law to do so shall not be liable in any way as a result of any reliance placed by any persons or anything contained in this document. Please consult with UD Trucks dealer for the latest information about vehicle specifications.
*Rated GVM and axle capacities are subject to federal, state and Territory legal requirements.

