

MODEL RANGE

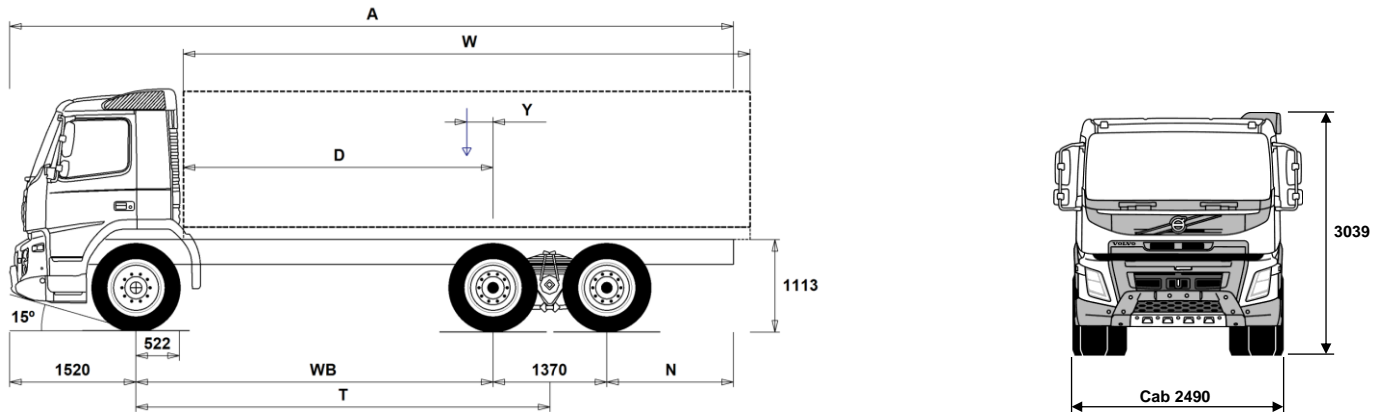

Volvo Trucks. Driving Progress

FMx13 HTX 6x4 Rigid T-Ride - Heavy Construction FM 64 R3HTX



Chassis Dimensions [mm]

WB Wheelbase	3700	3900	4600	4900
A Overall Chassis Length	8615	8915	10015	10465
D Center of rear axle to front of body	3128	3328	4028	4328
N Rear Overhang (Min.)	1225	1225	1225	1225
N Rear Overhang (Max.)	2025	2125	2525	2675
T Theoretical Wheelbase	4385	4585	5285	5585
Y Center of Gravity for Payload (Min.)	-124	-100	-16	18
Y Center of Gravity for Payload (Max.)	-124	-100	-16	18
W Body Length (Min.)	6444	6764	7884	8364
W Body Length (Max.)	6444	6764	7884	8364

Chassis Weights [kg]

Front Axle	4660	4665	4695	4715
Rear Bogie	3955	3970	4045	4090
Kerb Weight	8615	8635	8740	8805
Payload (including body, driver, fuel, etc.)	14385	14365	14260	14195

Turning Diameter [mm]

Turning Circle Diameter Kerb to Kerb	15500	16100	18200	19100
Turning Circle Diameter Wall to Wall	16900	17500	19700	20600

Plated Weights [kg]

	Plated	Design
Gross Vehicle Weight	23000	33500
Gross Combination Weight	42500	44000
Front Axle	6500	7500
Rear Bogie	16500	26000

Important Notes

Chassis Dimensions

Cab Height: +416 mm for CAB-HSLP.

Front Axle to Back of Cab: +424 mm for CAB-HSLP and CAB-SLP.

D-measure includes a front clearance of 50 mm and for rigid trucks also a subframe of 100 mm.

Height can vary ± 20 mm for leaf and ± 10 mm for air suspension.

All dimensions are for unladen chassis and any tag axles down. Chassis height used: CHH-HIGH.

Rear overhang used for vehicle weight calculation is the maximum rear overhang (N Max.) for selected wheelbase.

Weight and dimensions are based upon the following tyres:

Front Axle Tyres: 315/80R22.5
Drive Axle Tyres: 315/80R22.5

Chassis weight includes oil, water, AdBlue, 0 litres fuel and without driver. Kerb weight can vary $\pm 3\%$.

Turning diameters are theoretically calculated.

Legal weights can differ from country to country.

For more detailed weight information, including optional equipment weights, ask your Volvo sales contact to enter your specification into the Volvo Weight Information system (WIS).

Do NOT use this drawing for bodybuilding. Refer to Volvo Bodybuilder Instructions and chassis assembly drawing FM64R3HTX.

MODEL RANGE

FMx13 HTX 6x4 Rigid T-Ride - Heavy Construction FM 64 R3HTX

Truck use

- **RC-ROUGH** Operating class on/off road
- **TIPP-PRE** Tipper preparation
- **UNIFORM** Basic uniform vehicle

Core components

- **FMX-DAY** Day cab
- **FMX-SLP** Sleeper cab
- **EU5SCR-M** Eu5 SCR Selective Catalytic Reduction (mandatory)
- **D13C460** Engine, 13C litre, 460hp, 2300nm
- **D13C500** Engine, 13C litre, 500hp, 2500nm
- **D13C540** Engine, 13C litre, 540hp, 2600nm
- **EBR-VEB+** Volvo Engine Brake + (VEB+)
- **AT2612F** Volvo I-shift - 12 speed automatic transmission (2600nm)
- **PT2606** Powertronic 6 speed transmission (2600nm)
- **RTH2610B** Volvo RTH2610B hub reduction rear axles
4 planet gears per hub
Axle rating: 26,000 kg
115 tonne train weight
(Application approved)

Packages

- **AUDHIG** Sound System including standard non-touch SID screen
- **MEDIA** SID Touch Screen. Internet Portal Support only for Dynafleet
- **MEDIADF** SID Touch Screen. Onboard Vehicle & Internet Portal Support for Dynafleet
- **MEDIANDF** SID Touch Screen. Onboard Vehicle & Internet Portal Support for Dynafleet with Navigation

Chassis

- **FST-PAR** Parabolic leaf spring front suspension
- **FST-PAR3** 3 leaf parabolic front springs (stiffer than normal)
- **FAL10.0** Front axle load 10 tonnes
- **FAL7.5** Front axle load 7.5 tonnes
- **FAL9.0** Front axle load 9.0 tonnes
- **FSTAB** Front stabilizer, normal stiffness
- **FSTAB2** Front stabiliser bar increased stiffness
- **FSTAB3** Heavy duty front stabiliser bar
- **RAL26** Rear suspension load rating: 26,000 kg
- **RSTAB1** Rear stabiliser bar
- **ACTST-TO** Volvo Dynamic Steering
- **ASFE-PS** Dynamic steering active features with personal settings
- **PSP-FIX** Power steering pump with fixed displacement
- **PSP-VAR** Power steering pump with variable displacement
- **EBS-MED** Electronic Brake System (EBS) contains
ABS, Traction control, Hill start aid
Diff lock control, Brake assist
Wheel brake monitoring, EBS status
- **AUXPARK** Auxiliary parking brake
- **TRCO-12V** 24v to 12v trailer lighting voltage converter
- **TABS-12** 24v to 12v trailer ABS voltage converter
- **FST8080** Frame section thickness 8mm
- **FIL-EEEF** Liner (inner) from end of engine to end of frame
- **FIL-FBEB** Liner (inner) - front of bogie to end of bogie
- **FIL-FBEF** Liner (inner)- front of bogie to end of frame
- **FIL-TXEB** Liner (inner) - trans x-mem to end of bogie
- **FIL-TXEF** Liner (inner) - trans x-mem to end of frame
- **BBOX-L** Battery box mounted on LHS chassis rail
- **2BATT225** 2x225 Ah batteries
- **BATTAMP** Battery amperage indicator (in the DID)
- **MSWI-C** Isolation toggle switch LHS of chassis

- Standard Equipment
- Optional Equipment

For more detailed information about cab and powertrain equipment, please refer to separate specification sheets.

For all possible options and combinations of options please consult your Volvo sales contact who can create a specification to match your requirements using the Volvo Sales Support system (VSS).

The factory reserves the right to modify design and change equipment without previous notification.
The specification can vary from country to country.

- **MSWI-R** Isolation switch on key fob (press door lock twice to isolate)
- **R415A66** RHS 415 litre alloy fuel tank w/o step
Min volume 415l
Max volume 465l
- **UL-FUEL** LHS fuel tank not fitted
Min volume 195l
Max volume 195l
- **ADB064** AdBlue tank 64 litres
- **ADB090** AdBlue tank 90 litres
- **FCAP-L** Fuel tank cap with lock
- **ESH-RIGH** Muffler horizontal, right exhaust outlet
- **ESH-VERT** Muffler horizontal, vertical exhaust outlet on right hand side
- **EXST-SSP** Stainless steel exhaust stack
- **TRBR-HCR** Hand controlled trailer brake, reduced pressure
- **TRBR-STA** Stationary trailer brake control
- **TRB-STRE** Automatic trailer brake activation (stretch brake)
- **ATANK-AL** Aluminium airtanks
- **TL-LED** LED tail lights

Rims and Tyres

- **RT-ALDPD** 10 stud dura-bright alloy disc rims
- **RT-ALDU** 10 stud alloy disc rims
- **RT-ALPDU** 10 stud polished alloy disc rims
- **RT-STEEL** 10 stud steel disc rims
- **SPWT-D** Spare rim & tyre equal to drive
- **SPWT-F** Spare rim & tyre equal to steer
- **SWCP-T2** Transport mounted spare wheel
- **JACK-12T** 12 tonne capacity jack with brace
- **JACK-15T** 15 tonne capacity jack and brace
- **TOOL-BAS** Basic tools
- **TOOLKIT** Tool kit complete
- **INFLAHOS** Tyre inflation hose (20 metres)

Powertrain equipment

- **ASO-C** Crawler gears
- **ASO-ULC** Ultra low crawler gears
- **TRAP-HD** Heavy Duty Transmission Internals
- **PVT-EXT** Topography Information... by GPS positioning & central storage data
- **TP-CON** Construction application trans. software
- **TP-DIST** Distribution application trans. software
- **TP-HD** Heavy duty (GCM) control software
- **TP-LONG** Long haul application trans. software
- **AMSO-AUT** Manual gear shift in automatic mode.
- **AVO-ENH** AMT Vocational option - enhanced
- **APF-ENH** Enhanced I-shift PTO functions
- **CS43B-O** Volvo 430mm single plate clutch
- **TC-HWO** Transmission Oil Cooler
- **TC-MAOH2** High performance transmission cooler
- **AIRIN-HI** High air intake, roofline position
- **AIRIN-LO** Low air intake, rear of cab position
- **ACL1ST-S** Air cleaner with two stage filter element
- **24AL120B** High capacity alternator, 120 Ampere.
- **24AL150B** Alternator - 150 Amp
- **PTER-100** PTO engine rear mounted with flange DIN100/ISO7646
- **PTER-DIN** Power Take Off / splined shaft groove (female) DIN5462.
- **PTER1400** Rear engine mounted power-take-off with flange SAE 1410
- **HPE-F101** F1-101 Hydraulic pump rear engine mounted
- **HPE-F41** F1-41 Hydraulic pump rear engine mounted

MODEL RANGE

FMx13 HTX 6x4 Rigid T-Ride - Heavy Construction FM 64 R3HTX

- HPE-F51** F1-51 Hydraulic pump rear engine mounted
- HPE-F61** F1-61 Hydraulic pump rear engine mounted
- HPE-F81** F1-81 Hydraulic pump rear engine mounted
- HPE-T53** F2-53/53 twin flow hyd pump rear engine mounted
- HPE-T70** F2-70/53 twin flow hyd pump rear engine mounted
- HPE-V45** V1-45 variable pump rear engine mounted
- HPE-V75** V1-75 variable pump rear engine mounted

- PTPT-D** PTO DIN / Powertronic
- PTPT-F** PTO flange conn / Powertronic
- PTR-D** Low speed PTO with DIN connection
- PTR-DH** High speed PTO with DIN connection
- PTR-DM** Medium speed PTO with DIN connection
- PTR-F** Rear PTO trans.flange 100% speed
- PTR-FH** High speed PTO with flange connection
- PTR-FL** Low speed PTO with flange connection
- PTRD-D** PTO with 2 DIN connections rear + 1 DIN connection front
- PTRD-D1** PTO with 1 DIN + 1 flange connection rear + 1 DIN connection front
- PTRD-D2** PTO with 2 flange connection rears + 1 DIN connection front
- PTRD-F** PTO with 1 DIN + 1 flange connection rear

- HPG-F101** F1-101 hydraulic pump gearbox mounted
- HPG-F41** F1-41 hydraulic pump gearbox mounted
- HPG-F61** F1-61 hydraulic pump gearbox mounted
- HPG-F81** F1-81 hydraulic pump gearbox mounted

- EIDLESD** Engine idle shutdown - 2.5 mins
- DTRI-PER** Dashboard trim, peregrine/raven
- INST-MED** Mechanical instrument cluster with colour DID.
- 7DAYB** Seven Day Tachograph
- CRUIS-E** Extended cruise control (additional fuel saving functions)
- CRUISEC** Cruise control
- ACCLF-D** Acceleration Limiting Feature - disabled
- ACCLF-E** Acceleration Limiting Feature - enabled always
- ACCLF-S** Acceleration Limiting Feature - selectable
- ESP-BAS1** ESP package (tractor/trailer combinations with ABS. Rigid with standard COG)
- HWSS-ACB** ACC & forward collision warning & emergency braking.
- LSS-DW** With lane departure system
- LCS** Lane change support
- DAS-W** Driver alert support warning
- RSSENS-W** Rain sensor to activate wipers
- CU-ECC** Climate controlled air conditioning
- CU-MCC** Manual controlled air conditioning
- IMMOBIL** Engine immobiliser
- ALARM-B** Anti-theft alarm (cab)
- BUPMON** Back-up camera
- WLIFT-AD** Electric windows
- WLIFT-EB** Electric windows
- ISUNS-DS** Interior side sunvisor - driver's door
- ISUNF-B** Interior front sunvisor - standard
- ISUNF-MD** Interior front sunvisor - with mirror (driver's side)
- ISUNF-RE** Interior sunvisor - front (electric)
- ISUNF-RM** Interior sunvisor - front (manual)
- CSPU-S** Upper - cup holders & lower - storage area
- ADFS** 2 din slots in front shelf
- BUPALARM** Reverse alarm
- REMC-MF** Multifunction wireless remote control
- FIREX25A** Fire extinguisher 2.5 kg
- WRITEPAD** Storable steering wheel fit clip board
- UPHTRI01** Vinyl & Textile trim

- DST-CF5** Fully adjustable driver's comfort seat
Air suspension, heated, integrated safety belt
- SBD-RED** Red safety belts, pass. & driver seats
- SBPRE-DS** Drivers seat belt pretensioner
- PST-BAS1** Basic passenger's seat
- PST-BENC** Passenger bench seat
- PST-CF5** Fully adjustable passenger comfort seat
Air suspension, heated, safety belt
- SBPRE-PS** Passenger seatbelt pretensioner
- ARM-DBPS** Armrests driver's both sides - passenger side single
- ARMRE-BB** Armrests both sides - driver's & passenger's seat
- ARMRE-DB** Armrests both sides - driver's seat
- ARU-BAS** Seat armrest upholstery - basic
- GRABHI-B** Instep grab handle - standard
- FMAT-RU2** Floor mats - rubber (extended side)
- FMAT-RUB** Floor mats - rubber
- FMAT-TX2** Floor mats - textile & rubber
- LBK-RES** Foldable rest kit
- LBK70** Lower bunk 700mm wide
- ULBK** Without lower bunk
- MATL-FI** Mattress lower bunk - firm
- MATL-SF** Mattress lower bunk - semi firm
- OLMAT-BA** Mattress overlay - basic
- SAFE** Safe box at bed-end
- ETSB-F** Engine tunnel storage box
- ETSB-FR** Engine tunnel storage box & rear cab wall
- ETSB-R** Rear cab wall storage
- RUS-HIG** Rear upper cab storage - 245 litres, 440mm
- TABLE** Table
- REF-ICPK** Refrigerator prep kit (on engine tunnel)
- BOTH-D** Bottle holder in driving area
- INLI-BAS** Interior night lights
- INLI-NL** Interior white and red (night) light
- ARL-FLEX** Flexible reading lamp (snake light)
- RH-MSR** Roof hatch-manual - steel - rear opening
- SWIND-BS** Cab side window-both sides
- SWIND-PS** Cab passenger side aux. window
- VANMIR** Vanity mirror
- AS-FUS** Auxiliary shelf, front upper storage
- INFOT-PK** LCD screen mount - 6kgs max

Cab exterior

- EXTL-BAS** Standard exterior trim level
- PAICS-B** Grey mirrors, sun visor, instep & bumper
- AWIND-RF** Cab rear window- fitted
- DGLAS-L** Laminated door glass
- LOCK-CTL** Central door locking-Key
- LOCK-MAN** Manual door locking
- LOCK-REM** Central door locking with remote control
- BUMP-HD** Bumper-heavy duty
- GUARD-EH** Guard plate for cooling pipes and oil sump
- SIDEH-B** Side handle (driver's side)
- SIDSTP-R** Side ladder with handle (driver's side)
- BUGNET** Insect net in front of radiator
- CTILT-P-E** Electrical cab tilt pump

Standard Equipment Optional Equipment

For more detailed information about cab and powertrain equipment, please refer to separate specification sheets.

For all possible options and combinations of options please consult your Volvo sales contact who can create a specification to match your requirements using the Volvo Sales Support system (VSS).

The factory reserves the right to modify design and change equipment without previous notification. The specification can vary from country to country.

MODEL RANGE

FMx13 HTX 6x4 Rigid T-Ride - Heavy Construction FM 64 R3HTX

- **CTILTP-M** Manual cab tilt pump
- **FCABS-A** Front cab suspension-air bellows
- **FCABS-M** Front cab suspension-mechanical spring
- **RCABS-A** Rear cab suspension-air bellows
- **RCABS-M** Rear cab suspension-mechanical spring
- **MIRCOMFX** Electrically heated & operated convex glass mirrors
- **AMIR-F20** Close view mirror
- **SUNV-H** Exterior sunvisor
- **AD-ROOF** Aero-dynamic roof mounted deflector
- **AD-SIDES** Aero-dynamic cab side deflectors
- **GUARD-W** Windscreen stoneguard
- **HL-BAS2** Heavy duty headlamps
- **HL-BASIC** Standard head lamps
- **HL-CLEAN** Head lamp cleaning system
- **HLP-ST** Headlamp protection-steel
- **HLP-ST2** Headlamp protection-steel/wire mesh (non ADR compliant)
- **HL-ADJ** Headlight adjustment
- **DRL-LED** V-shaped LED daytime running light
- **IDLAMP-A** Identification lamps-amber
- **BEACON-P** Beacon light wire preparation
- **SPOTP-F** Aux spotlamp preparation, 280W maximum
- **ANT-CBR** Antenna for CB radio, single antenna

Superstructure

- **SRWL-2RW** 2 white rear chassis mounted working lamps
- **SRWL-PK** Wiring prep for chassis mounted reverse/working lamps-3 position switch
- **SWL-2FW** 2 white side working lamps (forward facing)
- **SWL-2RW** 2 white side working lamps (rearward facing)
- **SWL-4W** 4 white side working lamps
- **SWL-PK** Wiring prep for chassis-mounted working lamps-2 position switch
- **WL-CHPK** Chassis mounted working lamp prep kit
- **WLC-H2W** 2 x H3/70W high mounted work lamps with white lens.
- **WLC-PKH** Prep kit for high mounted work lamps.
- **WLC-PKL** Prep kit for low mounted work lamps.
- **WLC-PKLH** Prep kit for low and high mounted work lamps.
- **ECBB-HIG** Body builder module
- **BBCHAS3** Body builder chassis electrical interface, 3 x 7 pin connectors
- **BEPR-T2** Body Builder electrical prep. for tipper with remote control
- **EXSTER** External steering via body builder's module
- **HBA-SB** Holes for body attachments
- **AESW2** 2 flexible switches (AUX1 and AUX2).
- **AESW2PK** 2 flexible switches (AUX1 & AUX2) + additional 4 flexible switches
- **AUXSW-4** 4 extra bi-stable switches wired to BBM

Delivery services

- **TGW-3GWL** Telematics gateway with 3G & WLAN
- **FMS-PK** Fleet management system gateway
- **DRUT** "My Truck" smartphone app.

VOLVO

Volvo Truck Corporation
volvotrucks.com